

BENCH INSTRUCTIONS

BC1948

REV# 1
11/30/2016

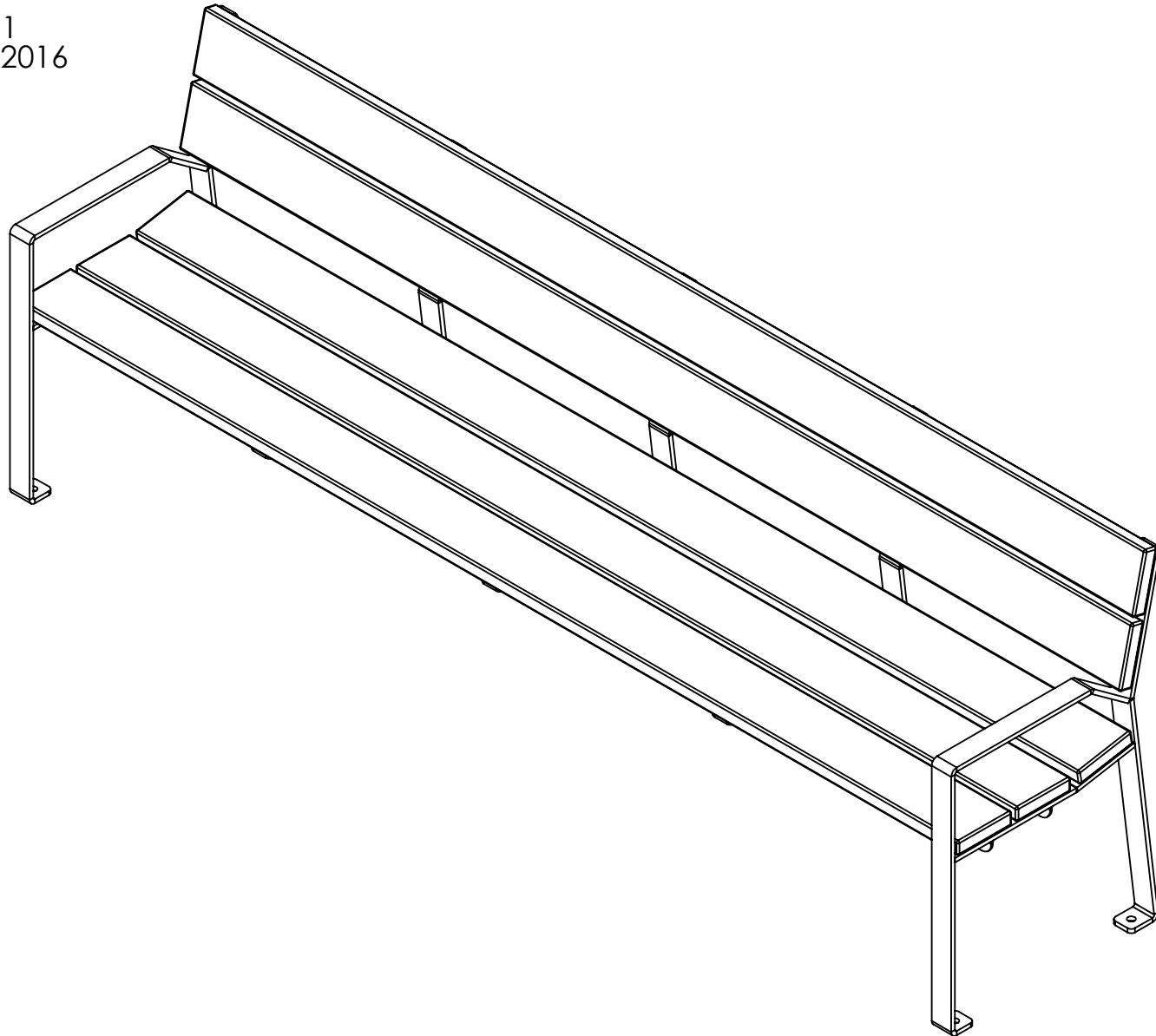

BENCH INSTRUCTIONS

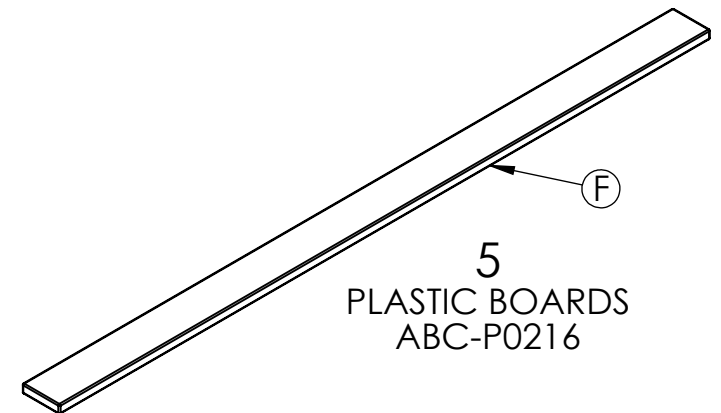
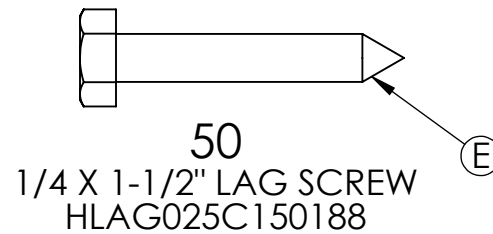
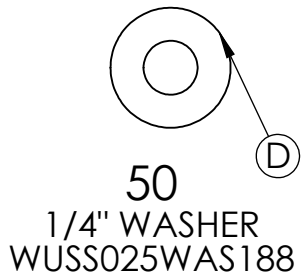
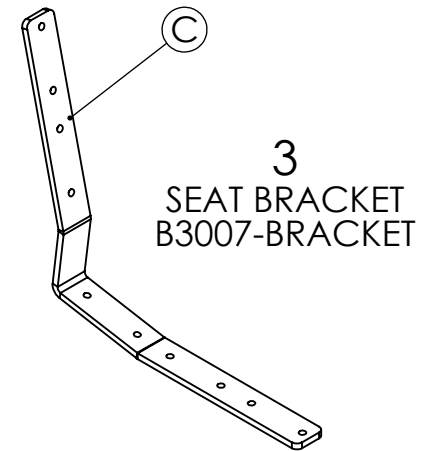
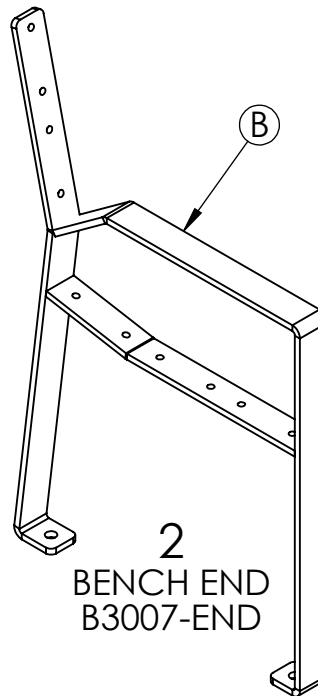
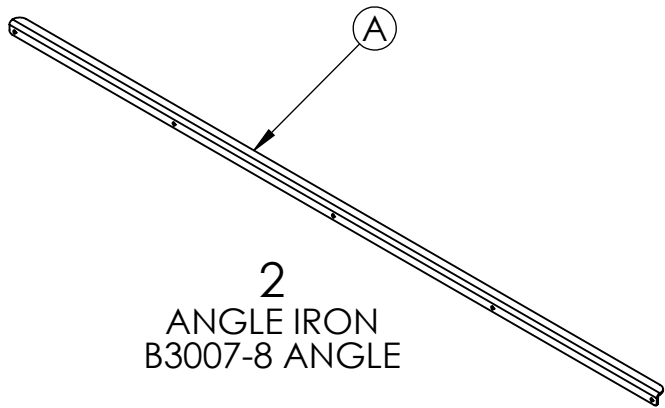

**REQUIRED TOOLS
(NOT INCLUDED)**
- 7/16 WRENCH / SOCKET
- 90 DEGREE SQUARE

**NOTE: IT IS IMPORTANT TO KEEP ALL SCREWS LOOSE
DURING ASSEMBLY UNTIL ENTIRE BENCH IS ASSEMBLED**

**HARDWARE &
TOOLS REQUIRED
FOR ASSEMBLY**

2/5

BENCH INSTRUCTIONS

STEP 1 Seat Assembly

- Set two bench ends (B) upside down on a table
- Lay a plastic board (F) under the end (B) closest to the back of the bench
- Align the holes on the plastic board (F) with the holes on the bench ends (B)
- Secure the bench end (B) with the 1/4x1-1/2" lag screws (E) thru the 1/4" washer (D) thru the end (B) into the plastic board (F)

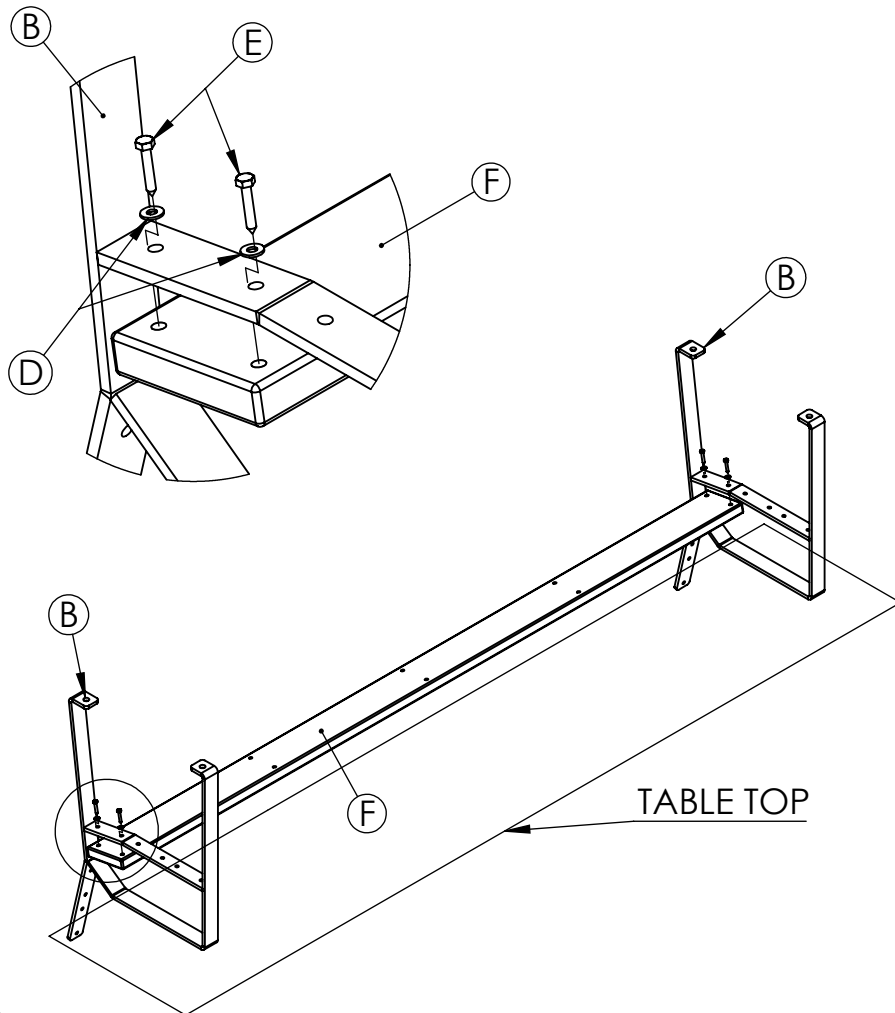

STEP 2 Seat Assembly

- Lay the seat bracket (C) on the plastic board (F)
- Align the holes on the plastic board (F) with the holes on the seat bracket (C)
- Secure the seat bracket (C) with the 1/4x1-1/2" lag screws (E) thru the 1/4" washer (D) thru the bracket (C) into the plastic board (F)

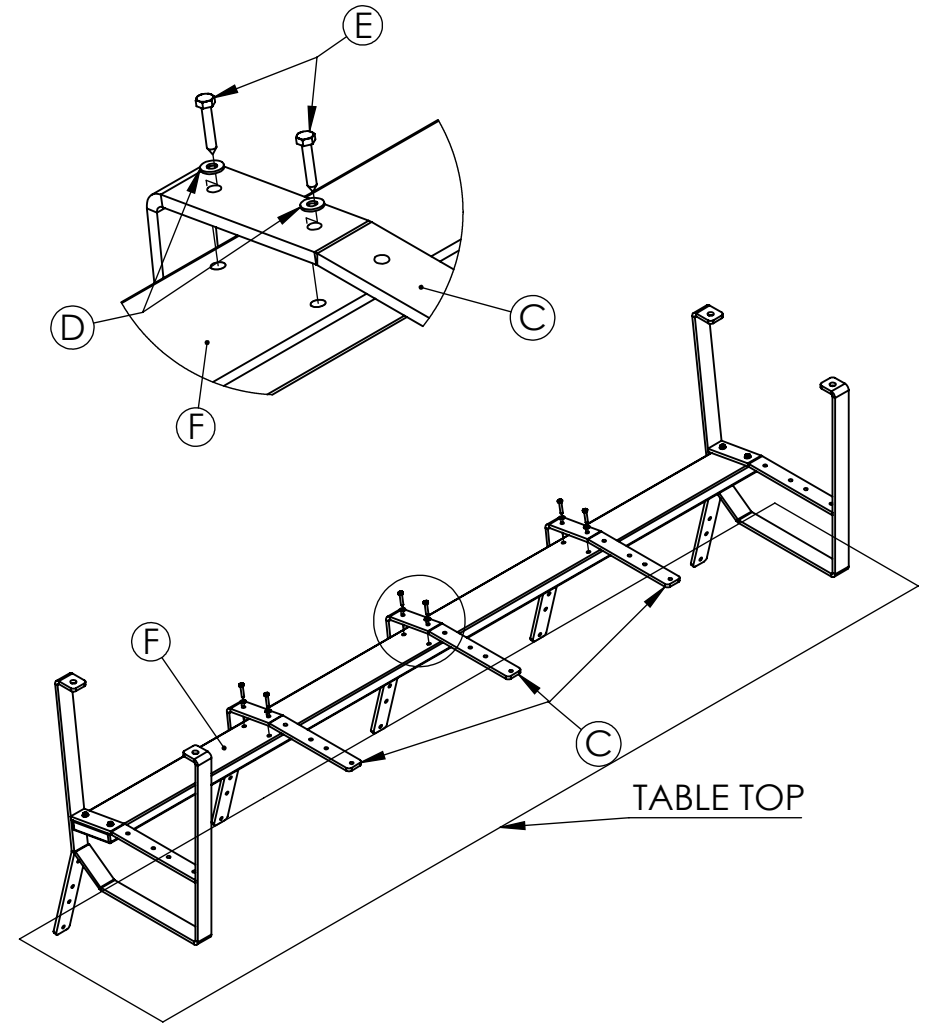

BENCH INSTRUCTIONS

STEP 3 Seat Assembly

- Lay a plastic board (F) under the end (B) and under the seat bracket (C)
- Align the holes on the plastic board (F) with the holes on the bench ends (B) and seat bracket (C)
- Secure the board (F) with the 1/4x1-1/2" lag screws (E) through the 1/4" washer (D) through the end (B) and seat bracket (C) into the plastic board (F) in the front hole
- Align the angle iron (A) with the holes on the bench ends (B) and seat bracket (C)
- Secure the board (F) with the 1/4x1-1/2" lag screws (E) through the 1/4" washer (D) through the angle iron (A) into the plastic board (F) in the rear hole
- Repeat for remaining seat board

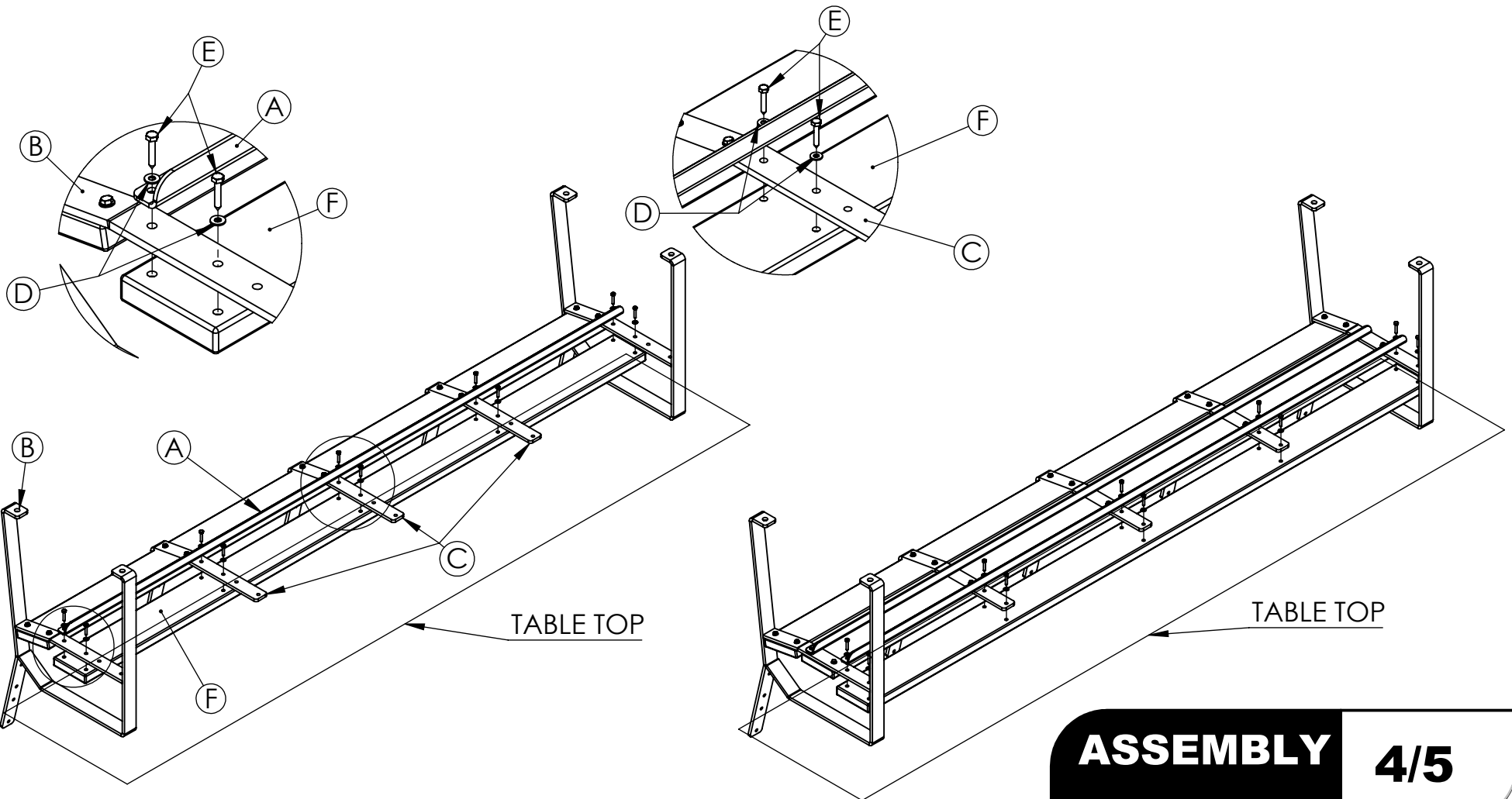

BENCH INSTRUCTIONS

STEP 4 Backrest Assembly

- Remove bench from the table and set upright on a level surface
- Hold a plastic board (F) up to the back rest portion of the bench end (B)
- Align the holes on the bench end (B) with holes on the plastic board (F)
- Secure the board (F) with the 1/4x1-1/2" lag screws (E) thru the 1/4" washer (D) thru the end (B) and seat bracket (C) into the plastic board (F)
- Square all components and tighten all screws

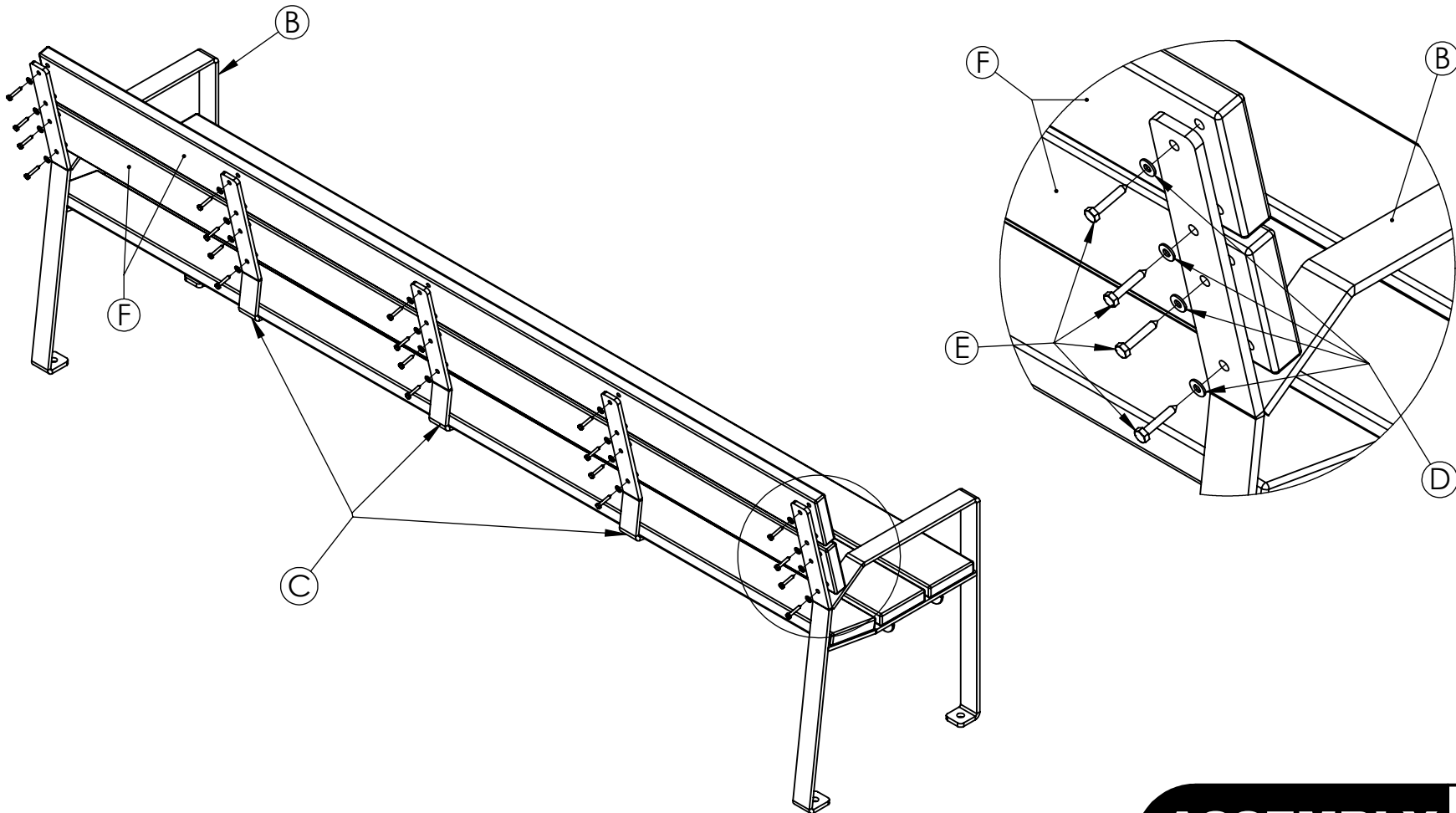

BENCH SPECIFICATIONS

BC1948

TOP

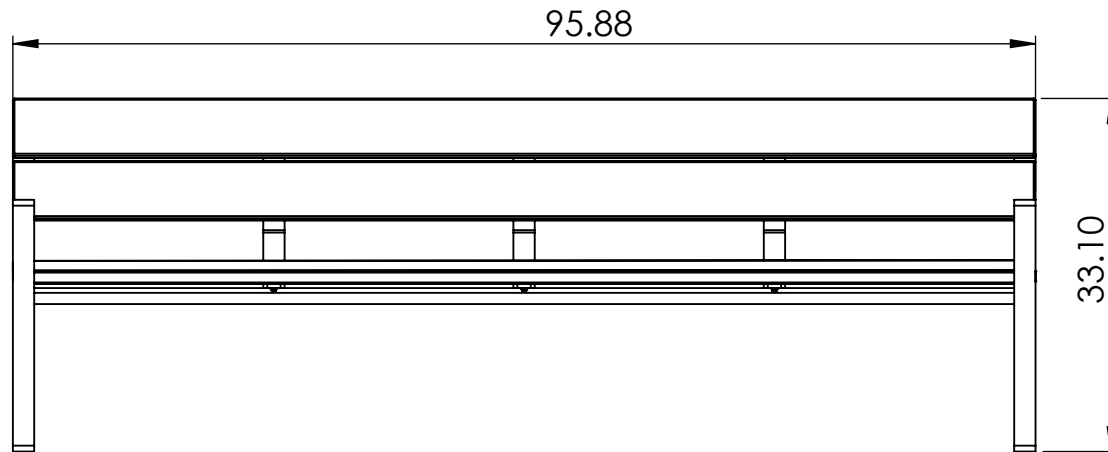
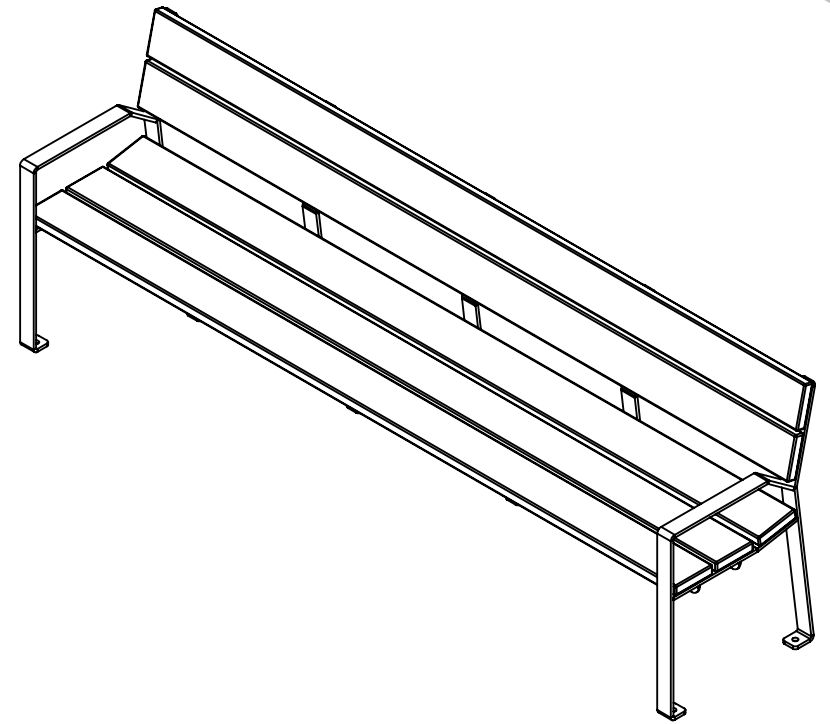
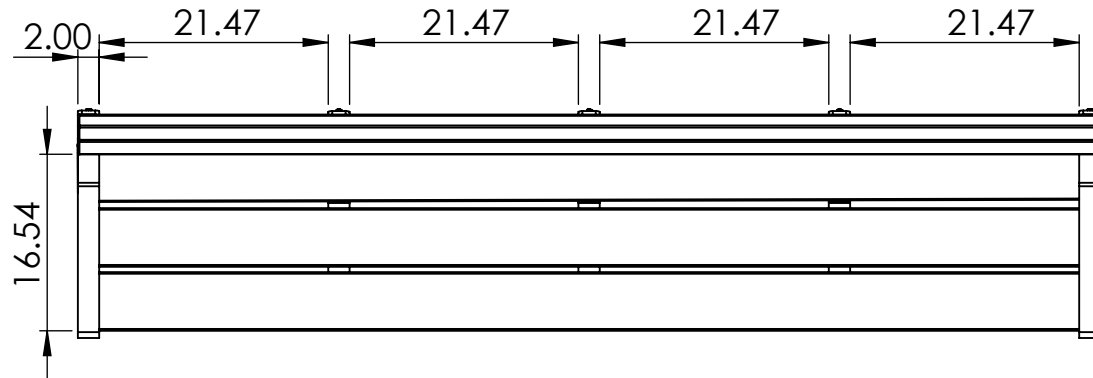

FRONT

CONSTRUCTION MATERIALS:
Recycled Plastic
HARDWARE:
Stainless Steel

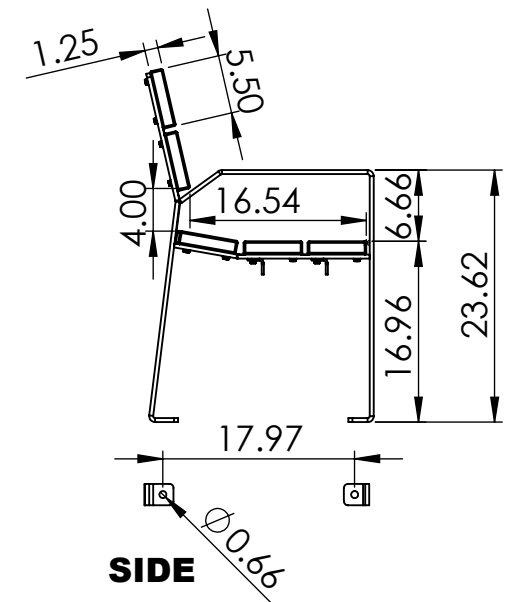

SIDE

ALL DIMENSIONS ARE SHOWN IN INCHES