

BENCH INSTRUCTIONS

BM1135

REV# 1

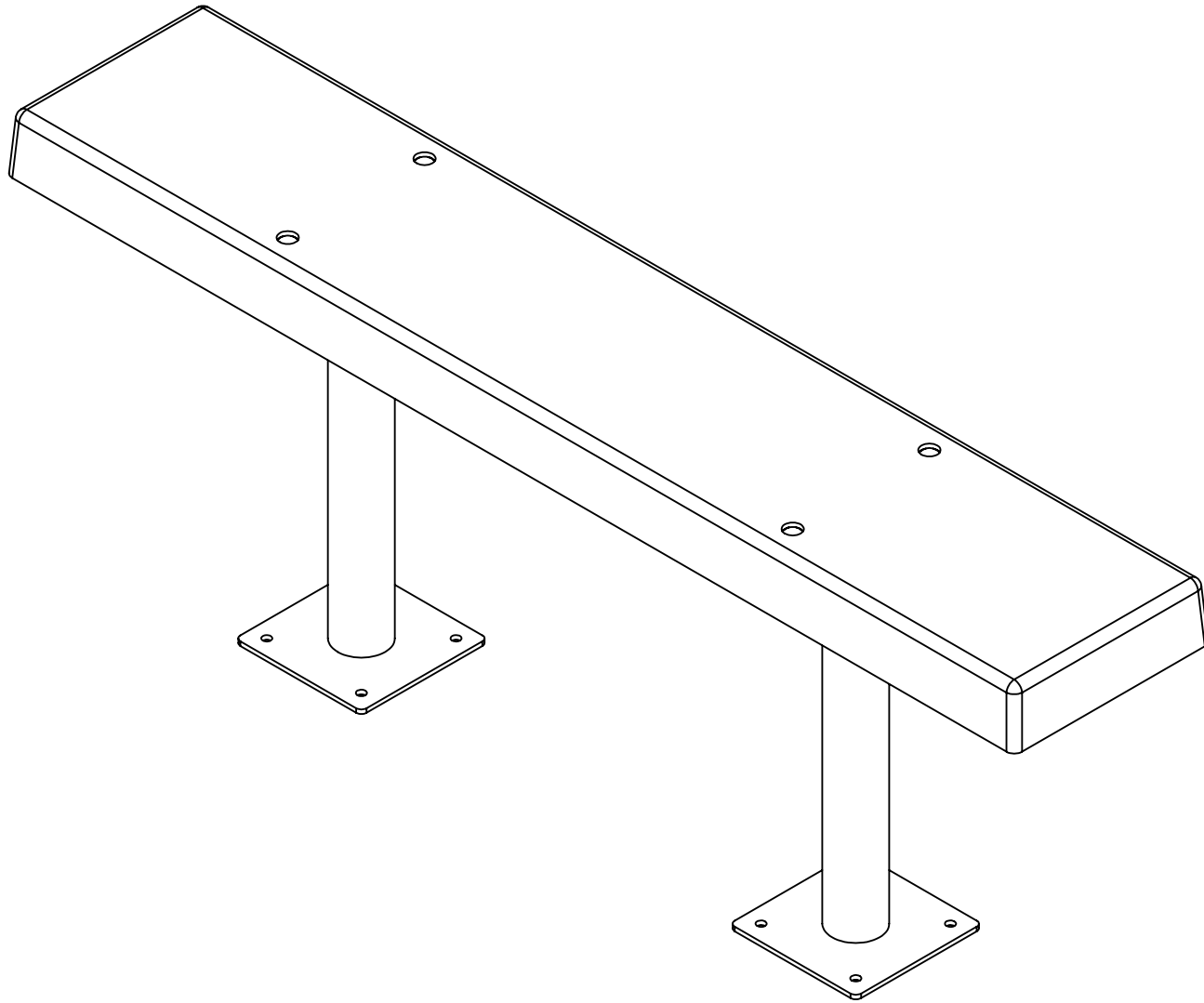

BENCH INSTRUCTIONS

BM1135

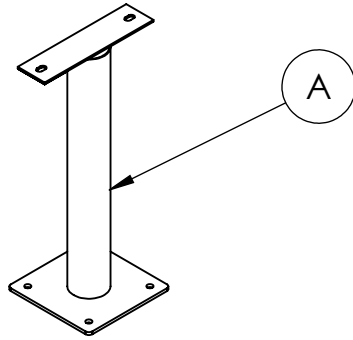

2
STEEL BENCH END

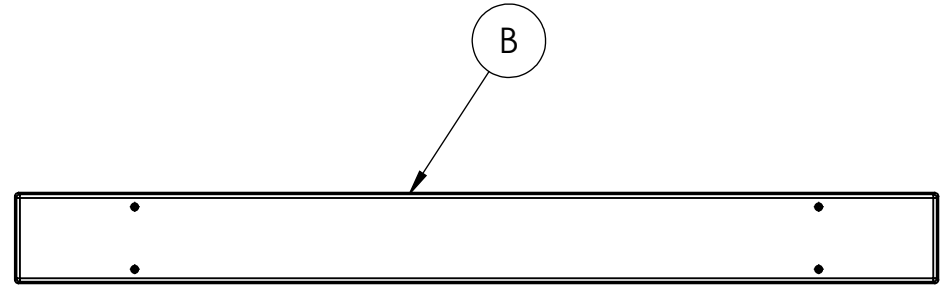

1
PLASTIC BOARD

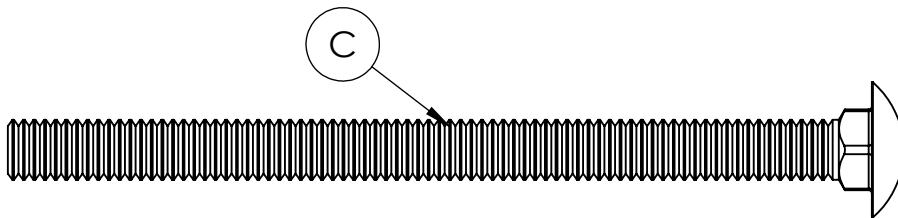

4
4-1/2" X 5/16" CARRIAGE BOLT

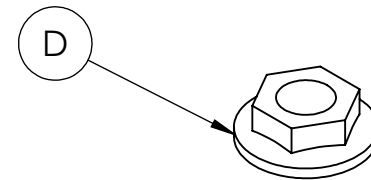

4
5/16" FLANGE NUT

REQUIRED TOOLS (NOT INCLUDED)

- 1 - 1/2" WRENCH
- 1 - 1/2" SOCKET

NOTE: IT IS IMPORTANT TO KEEP ALL BOLTS FINGER TIGHT DURING ASSEMBLY UNTIL ENTIRE TABLE IS ASSEMBLED

**HARDWARE &
TOOLS REQUIRED
FOR ASSEMBLY**

2/3

BENCH INSTRUCTIONS

BM1135

STEP 1

- Set the two steel bench ends (A) 21 inches apart
- Lay the board (B) over the steel bench ends (A)
- Insert two 3-1/2" x 5/16" carriage bolts (C) into the holes in the boards (B) and through the steel bench ends (A)
- Hand tighten with two 5/16" flange nuts (D)
- Repeat on opposite bench end

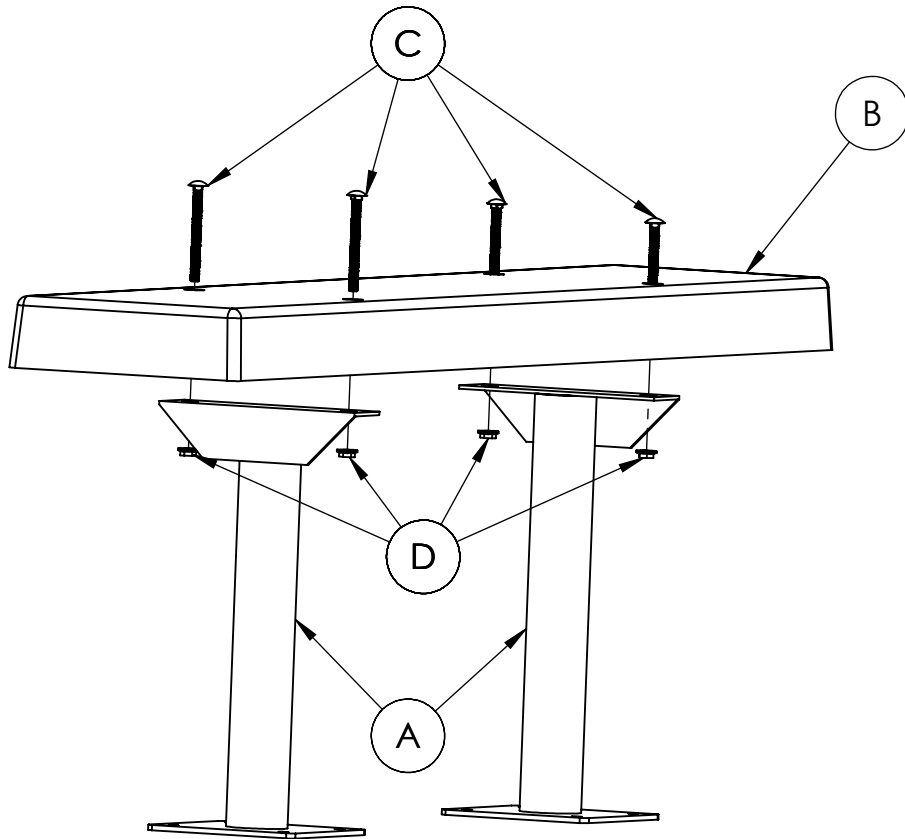

STEP 2

- Square all parts and tighten all hardware
- Install on a flat level surface with appropriate hardware

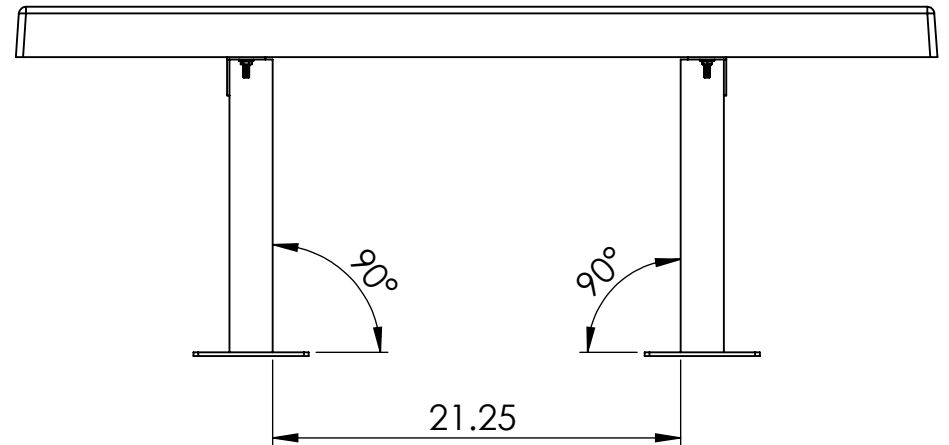

BENCH SPECIFICATIONS BM1135

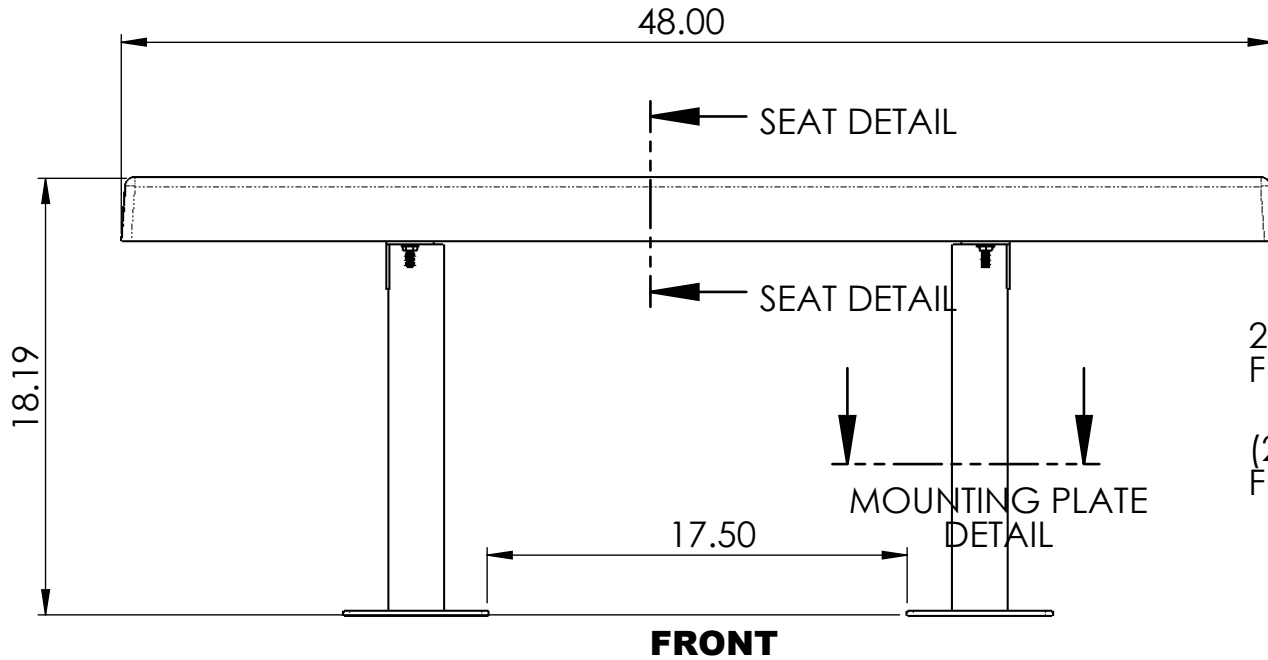

2" X 2" ANGLE SUPPORT
FINISH: POWDER COAT BLACK

(2) 16 GA - 2.25 OD TUBE
FINISH: POWDER COAT BLACK

(2) 7 GA - 6" X 6" PLATE

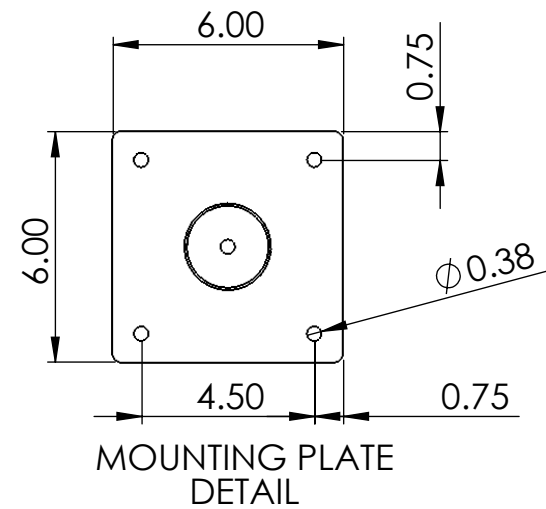
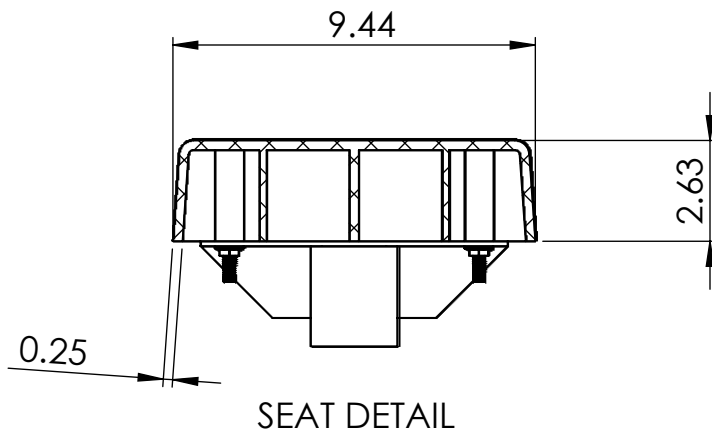
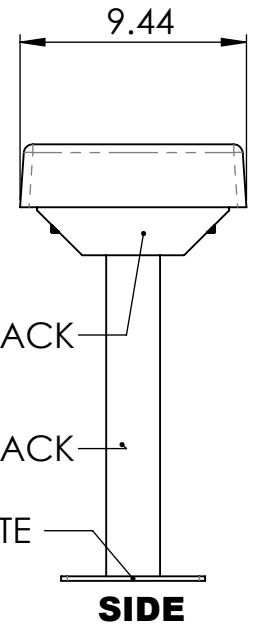

ALL DIMENSIONS ARE SHOWN IN INCHES